



**CORPORATE**

Arrjavv Square  
95A, Elliot Road, 4th Floor  
Kolkata 700 016, India  
For Enquiry call: 033-4190-0001  
Website: [www.utkarshindia.in](http://www.utkarshindia.in)

**PLANT 1**

NH6, Vill-Jangalpur, P.O. Andul Mouri  
Howrah 711 302, India

**PLANT 2**

NH2, Durgapur Expressway, P.O. Gurap  
Hooghly 712 303, India

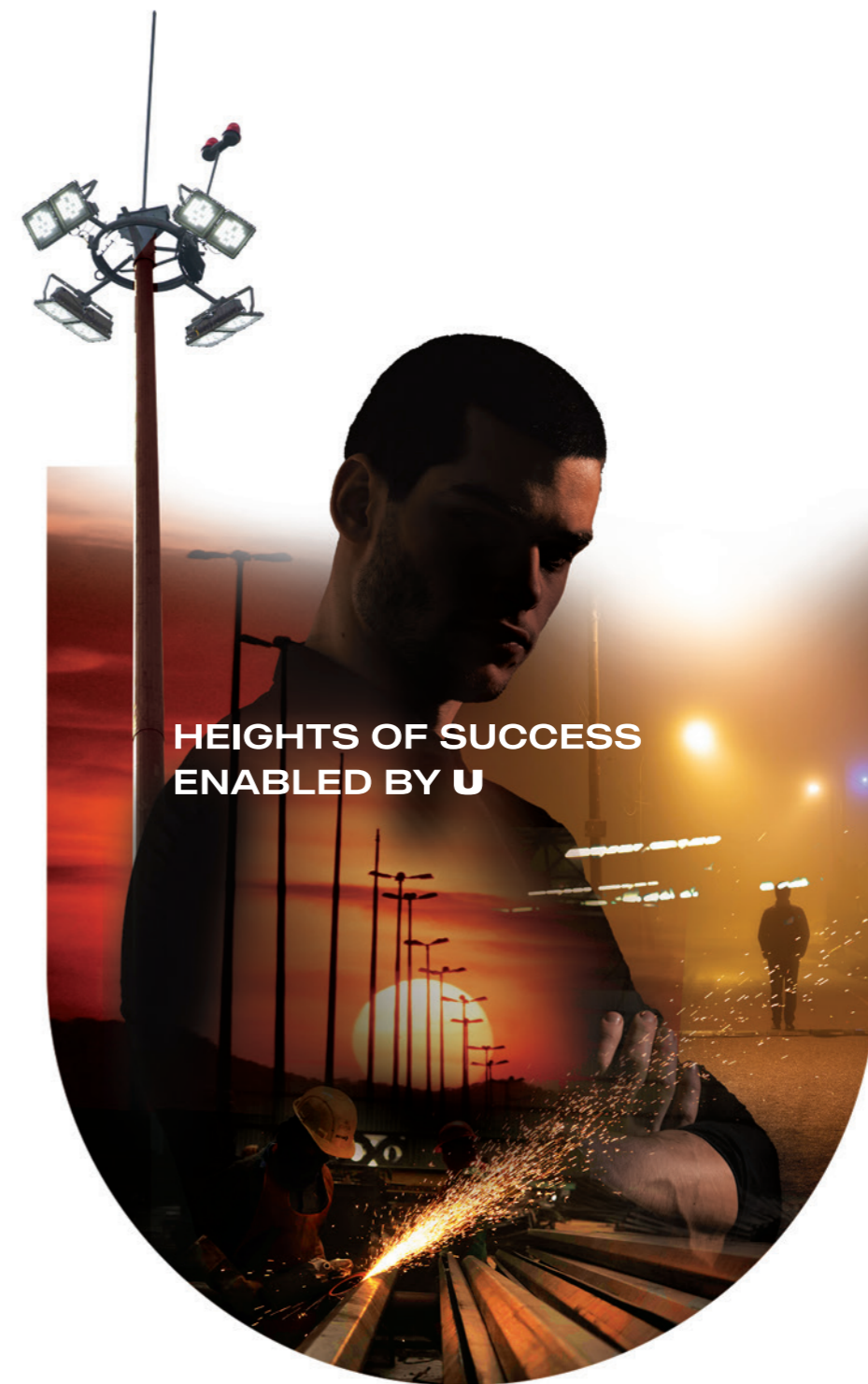

**HEIGHTS OF SUCCESS  
ENABLED BY U**

**HIGH MAST  
STRUCTURES AND STREET  
LIGHTING POLES**







# U Are Our Commitment

'Utkarsh', or excellence, is more than just our name; it is the passion that powers all we do.

In every product and service, our commitment is to deliver the highest quality to our customers. Our solutions are customized to best serve your specific requirements, and to meet global standards of quality, because the philosophy of 'customer is king', is the very foundation of our business. Which is why, you can always count on us to provide exactly what you need, on time, every time.

After all, Utkarsh always begins with U.





## What We Do For U

We are an ISO 9001:2015 certified organisation with annual turnover of over 2000 crore; a core engineering enterprise with over 40 years of expertise and excellence in steel fabrication, galvanization, plastic extrusion and moulding. We offer trusted one-stop solutions for all need-based applications, from design, engineering, rolling, forming to fabrication and galvanizing. Located at Gurap and Jangalpur in West Bengal, our world-class infrastructure and manufacturing facilities are spread over 30 lakh sqft, making us the preferred infrastructural partner in both public and private sectors, catering extensively to global and Indian client requirements.

With a highly skilled permanent and contractual workforce of over 4000, all our products are crafted with heart and perfection. Combined with our wide network of vendors, logistics services, raw material suppliers and capital goods suppliers, together we constantly strive to deliver nothing but the best to our clients.

## Our Promise To U

### MISSION

To deliver world-class products and services at competitive prices, through leading-edge solutions in technology and processes. To provide opportunities for inclusive growth to our employees by nurturing human resources. To share the pride of success with all our partners.

### VISION

To be the industry benchmark across all verticals, the preferred partner to our customers and stakeholders, by creating value and demonstrating high ethical standards.



## Globally Local For U

Our world-class products and stringent quality control have made Utkarsh a global choice today. Responding to growing demands, we serve clients in Germany, Belgium, UK, Lithuania, Poland, Northern Ireland, Australia, New Zealand, Canada, UAE, Qatar, Kuwait, Iraq, Reunion Islands, Madagascar, Malawi and Sri Lanka.

## Our Offerings For U

### **BUSINESS VERTICALS**

- High Mast Lighting Structures
- Railway Electrification Structures
- Polygonal & Octagonal Poles
- Steel Tubular Poles
- Metal Beam Crash Barriers
- Mild Steel and Galvanized Steel Pipes
- Polymer Pipes, Fittings, and accessories
- Transmission Line Towers for electrification
- Telecom Towers for communication
- Water Tank Metal Structures
- Pre-Fabricated Building Structures

## Why We're Right For U

Utkarsh India provides all infrastructural & manufacturing requirements under one roof.

- We have highly competent in-house design as well as research & development laboratories
- We host well-equipped, cutting-edge in-house testing facilities
- We have a sound financial standing to accomplish manufacturing target deadlines
- Our MOUs with leading National and International raw material manufacturers allow superior quality and easy procurement
- We are equipped with ample stock holding area for finished products as well as raw material storage
- Our manufacturing units are closely connected via seaports, national highways and railways
- We possess excellent vendor management skills with committed after-sales support



## DIRECTORS' MESSAGE

# From Us To U

Dear Friends,

Living by John Henry Newman's philosophy - "Growth is the only evidence of life", we have evolved into Utkarsh India Limited from Utkarsh Tubes and Pipes Ltd., by diversifying into infrastructural solutions. A nation's growth undoubtedly lies in its infrastructural development. This is but a humble step in that direction.

Expanding our horizons beyond national borders, we have been touching more lives by aiding infrastructural development across the globe, proudly contributing to the growth of foreign nations. A feat like this would have been impossible without the invaluable support of our esteemed suppliers, distributors and dealers. I extend my deepest gratitude to them.

Without an innovative, talented and passionate team of smart and far-sighted people, scaling the mountains of success over the last 40 years, would have been but a dream. A strong and experienced management ensures a smooth flow of the inner workings, much like our pipes. Utkarsh's adeptness stems from this seamless coordination among management, co-workers and our associates.

Sticking to our corporate ethos of 'U are our commitment', we bring the strong promise of consistency and reliability, ensuring optimum consumer satisfaction. 'Customer first' is the motto that drives us to bring you quality.

Regards

**Sunil Bansal, CMD**

We are committed to ensure a customer centric, service oriented approach across all our products and offerings.

**Utkarsh Bansal**

Director, Business Strategies





# Illuminating India For U

As a leading brand in the lighting mast & street lighting pole industry, our commitment is to brighten the lives of people around the world. As a brand approved by Government departments, PSUs and Corporates, we have manufactured and supplied over 10 lakh Polygonal Poles and 50,000 Lighting Masts. And we have been part of every prestigious national and global project, thanks to our 2 decades of expertise.

**1,000,000 + Polygonal Poles**

**50,000 + Lighting Masts**

**HIGH MAST  
STRUCTURES  
AND STREET LIGHTING  
POLES**



## THE UTKARSH ADVANTAGE

- Largest brand for the production of Lighting Masts and Street Lighting Poles in India (Octagonal/Polygonal/Conical/Swaged).
- Production capacity of more than 300,000 units/annum of Poles & 10,000 units/annum of High Mast Lighting Systems, each with committed delivery time
- Vetted design software for secure High Mast structure design by Jadavpur University, Kolkata
- Wind Tunnel Test certifications from IIT Kanpur for performance analysis
- State-of-the-art manufacturing machinery & plant setup managed by highly qualified manpower
- 5 in-house seven-tank galvanization setups, each with 12.5 metre-long GI Bath
- Successful installation of 50,000 Lighting Masts & 1,000,000 Lighting Poles with dedicated after-sales support



## QUALITY ASSURANCE

At Utkarsh India, we follow the strictest industry norms to adhere to our supreme quality requirement standards.

- NABL Certificates for material-testing of Mast Shaft, Base Flange & Foundation Bolt (as per IS:2062)
- Lantern Carriage Material tests conforming to IS:1161 / 1239 standards
- NABL Certificate for Head Frame Die Cast Al Pulley and SS Shaft testing
- SS Wire Lifting Rope quality checks as per AISI 316
- Winch Lowering Mechanism & EPR, PCP Rubber Coated Trailing Cable verified as per standards
- Lighting Mast's Structural & Galvanization quality maintained as per IS:4759



# High Mast Products Details

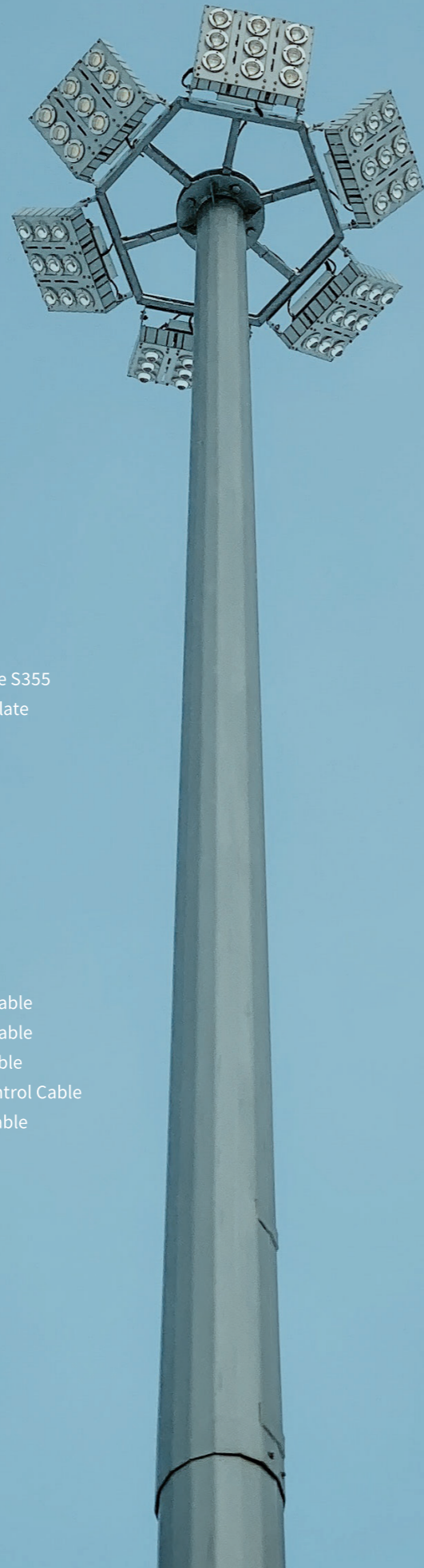

## APPLICABLE STANDARDS FOR HIGH MAST & POLE

### STRUCTURAL DESIGN

- Technical Report No. 7 of ILE UK / PLG - 07 of ILP - Design & Construction of Mast
- BS EN 1993 - 1 - 9.2005 Fatigue
- IS 875 Part - 3 - 2015 Wind Loading
- IS 1893 Seismic
- EN 40

### RAW MATERIAL INSPECTION

- BS EN 10025:1993 High Tensile Steel Plate grade S355
- IS 2062:2011 / BS EN 10025 - 2:2019 Mild Steel Plate
- IS 1367:2002 Foundation Bolt

### MANUFACTURING PROCESS

- BSEN 1011 - 1 Submerge Ark Welding
- BS EN ISO 1461 / IS 2629 Galvanization

### ACCESSORIES FOR HIGH MAST

- IS 9507 / BS 3701 Winch
- IS 3459 / 2266 Stainless Steel Wire Rope
- IS 9968 Part - 1 Elastomeric Insulated Trailing Cable
- IS 9968 Part - 1 Elastomeric Insulated Trailing Cable
- IS 694 PVC Insulated, PVC Sheathed Flexible Cable
- IS 1554 Part - 1 LT PVC Insulated Power and Control Cable
- IS 7098 LT XLPE Insulated Power and Control Cable
- IS 325 / IS 12615 LT Motor
- IS 13947 Electric Panel
- IS 456 / IS 2911 Foundation
- ICAO Guideline

# Manufacturing Process

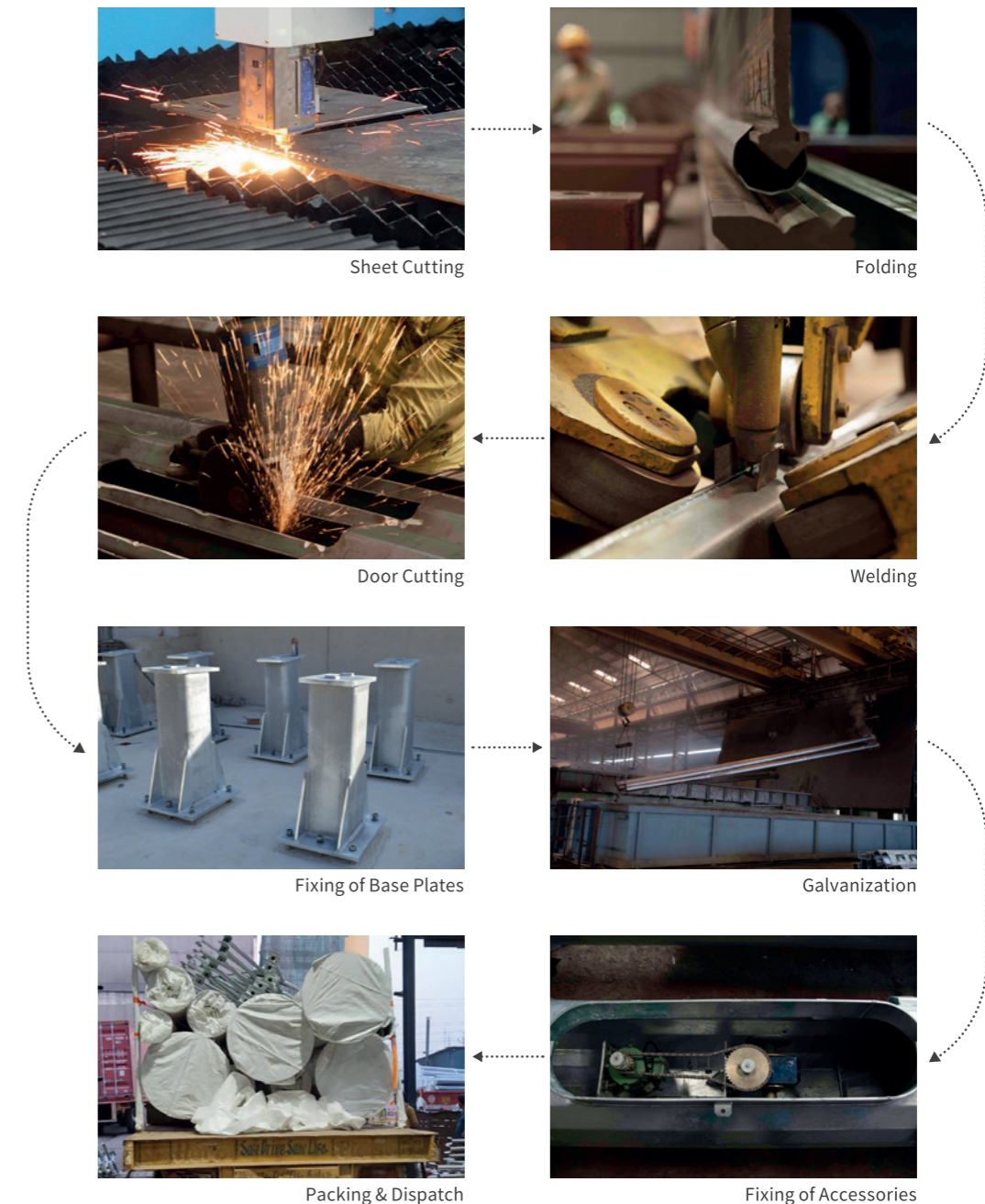



# Product Range



**HIGH MAST LIGHTING SYSTEM**  
(10m - 60m)



**OCTAGONAL & CONICAL STREET LIGHTING POLE**  
(10m - 60m)



**DECORATIVE LIGHTING POLE**  
(Starts from 3m – Length & Design as per requirement)

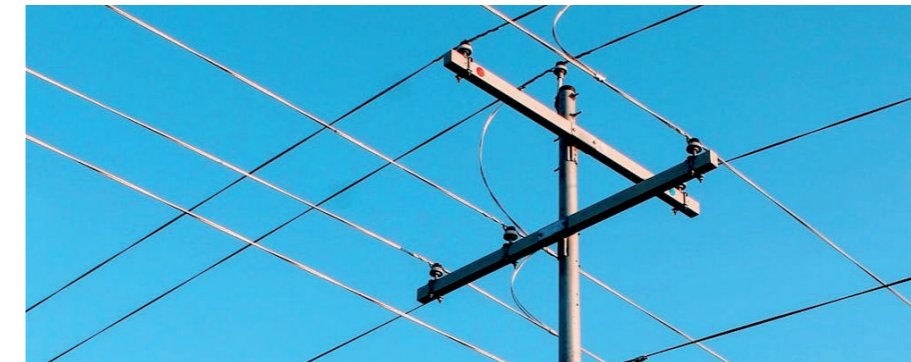

**UTILITY POLE**  
(Starts from 5m – Length & Design as per requirement)

- Camera Pole
- CCTV Pole
- Gantry Pole
- Smart Pole
- Distribution Pole



**SPORTS LIGHTING STRUCTURE**  
(16m – 60m)

- Stadium Mast with Man-rider
- Stadium Mast with Ladder



**SIGNAGE MAST STRUCTURE UNIPOLE**  
(10m – 60m)



**SOLAR POLE & MAST STRUCTURE**  
(3m - 20m)

- Solar High Mast
- Solar Pole



**FLAG MAST**  
(10m - 60m)



# Specifications Of High Mast

The High Mast structure is fundamentally designed to withstand wind speeds at the region of installation. The top load (weight & windage area) of fixtures and Lantern Carriage/Head Frame with accessories are also considered in the structural stability calculation. The ratings of electrical components are calculated based on the lighting load at the top section.

## DESIGN

The High Mast structure ranging in height from 10 to 60 metres, is continuously tapered to be 20 sided polygonal cross-section, fabricated from specially manufactured steel sheets. The Mast Shafts are constructed from high tensile steel plates having a minimum yield strength of 355 N/sq mm with one or two longitudinal welds and without any circumferential weld joint. The Base Plate of the mast is welded internally and externally with the bottom section of the shaft. For ease of transportation, the length of each section is limited to a maximum of 12.5 metres. Sections are joined on-site by the slip-stress-fit method with a minimum overlap distance of 1.5 times the diameter at penetration. The A/F dimension of the top & bottom and the sectional thicknesses of each plate are done as per the structural design specifications.

Galvanized Steel Foundation Bolt sets of EN.8 grade/E250 in required quantity, suitable diameter, and suitable length are provided with the mast as per specified design calculations.

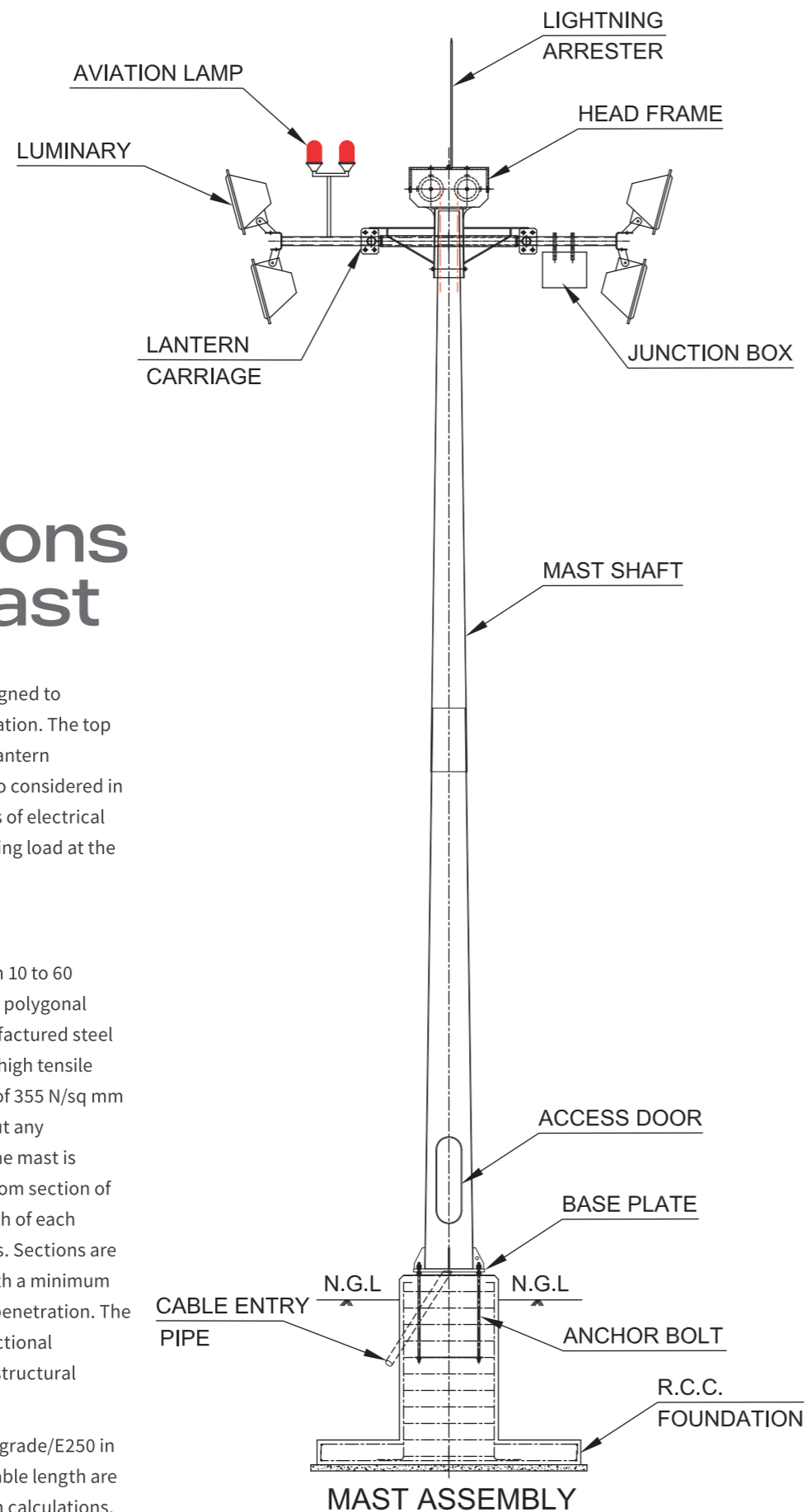

## FOUNDATION BOLT

Mast Shafts are internally and externally hot-dip galvanized in a single dip having an uniform average thickness of 85 microns for plates with more than 5 mm thickness and of 70 microns for plates with thickness of 5 mm or less in a bid to provide protection to the metal from environmental damages. Externally, PU paint is provided on galvanization to protect the mast in highly corrosive atmospheres like chemical plants, seaside, etc., and on-demand safety colour codes are provided on the structure to avoid any accidental mishaps in busy traffic areas.

## GALVANIZATION

The standard design life of the mast is 25 years. Designs for a longer life are available on demand.

## DESIGN LIFE OF MAST

Two red-coloured Low-Intensity LED Aviation Obstruction Lights are provided on the Luminaire Carriage section.

## DOOR

A vandal-resistant, weatherproof door with Allen bolts and padlocking facility is provided at a height of 500 mm from the Mast Flange for easy access to equipment inside the base component for maintenance purposes. Doors are structurally protected using reinforced, welded steel sections.

## EARTHING TERMINALS

Earthing Terminal with hot dip galvanized bolts of 12 mm diameter, shall be provided on the base plate stiffener of the mast for lightning and electrical earthing purposes.

## LIGHTNING FINIAL

A heavy-duty 1.2 metre long hot dip galvanized Lightning Finial is supplied with each mast on the Head Frame to get a direct conducting path to the earth through the Mast Shaft. Single core, Copper-armoured down conductor is provided on request from the Lightning Finial to Mast Base as a faster path for electricity in sensitive areas like power substations, iron ore mines, and oil installations.

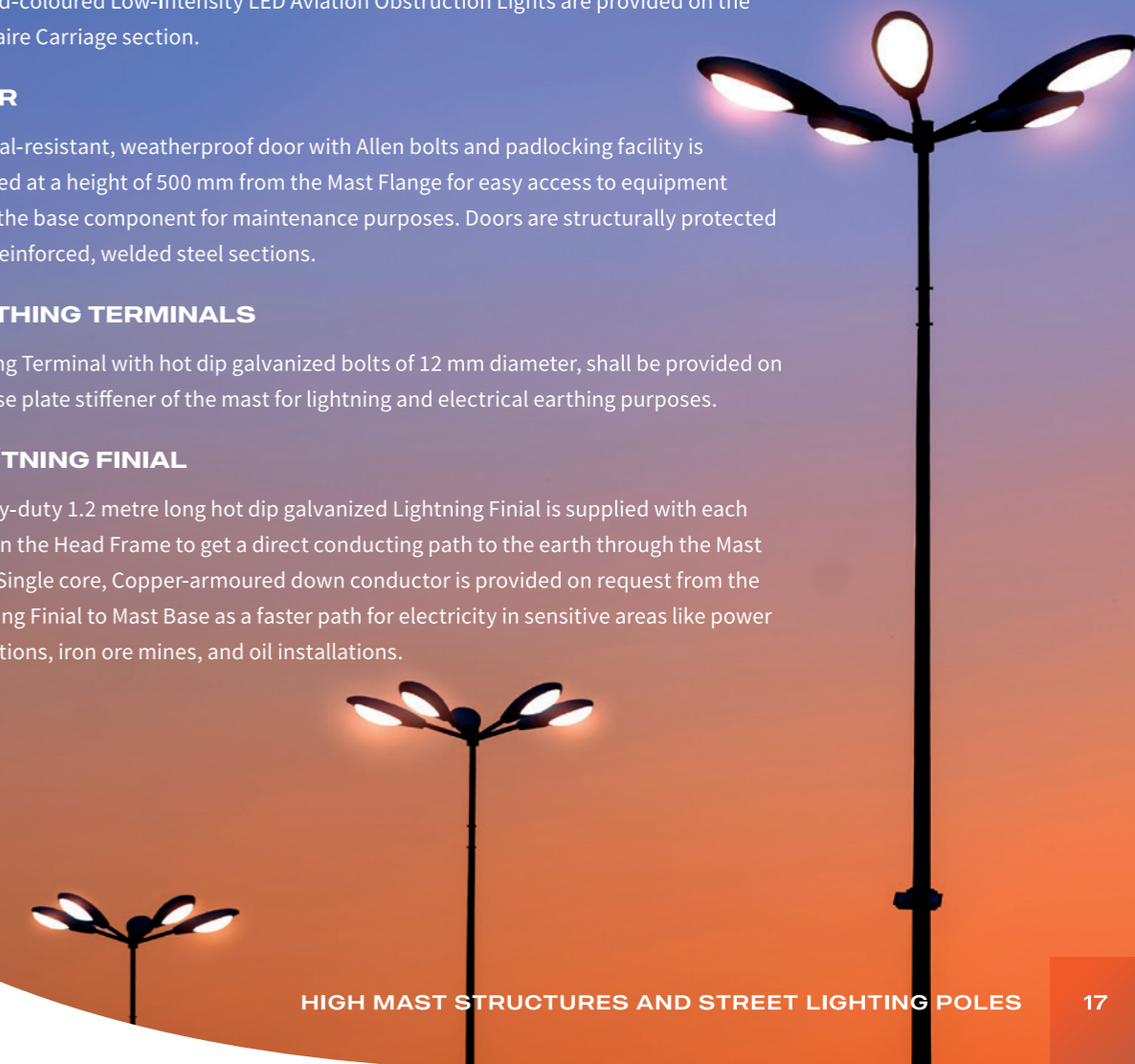



## HIGH MAST LIGHTING SYSTEM (Lantern Carriage & Manrider)

Hot dip galvanized Luminaires Carriage or Lantern Carriage is structurally suitable to install up to 24 light fittings including accessories and a Junction Box for distribution. The Luminaires Carriage is fabricated from ERW tubes in two halves and the flanges are joined on-site with galvanized stainless steel bolts and nuts. Holes are provided on the bottom side of the tubes for drawing the wiring cables. PVC/HDPE lining is to be provided on the inner side of the carriage to avoid direct metal contact with the mast surface.

### LANTERN CARRIAGE

The hot dip galvanized Head Frame is a capping unit of the mast. It acts as a separator between the Wire Ropes and cable. The LM6 Aluminium pulleys with bush bearing are mounted through the stainless steel shaft and are suitable to accommodate Wire Ropes and multi-core trailing cable. For docking the Luminaires Carriage, the Head Frame guides and stops using the PVC/HDPE buffer. The pulley assembly shall be protected by a hot dip galvanized canopy.

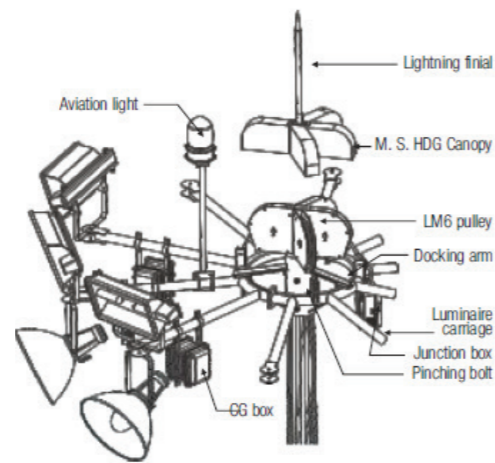

Mast Head Assembly with 3 rope head frame for 2/3 rope system

### HEAD FRAME

The Double Drum Winch has to be completely self-sustaining, without the need for brake shoes, springs, or clutches. The worm gear ratio shall be 53:1 / 50:1 and the safe working load has to be 750 kg. The drums are to be grooved to provide a perfect seat for the Wire Rope. The Winch shall have provision to be operated manually by a handle or electrically through a power tool. The capacity, operating speed, safe working load, recommended lubrication, and corresponding serial number will be marked on each Winch.

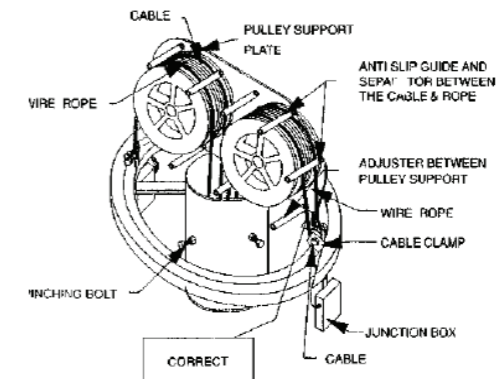

Pulley Assembly

### WIRE ROPE

The Stainless Steel Wire Ropes shall be in AISI 316 grade, 7/19 construction with a central core in the same material of 6 mm diameter. The breaking load of each rope can't be less than 2350 kg, giving a safety factor of over 5 for the system at full load, as per the TR-7.

### POWER TOOL FOR WINCH

Three-phase, single-speed, 6-pole high-powered Motor Tool of suitable rating is used to lift the load mounted on the adjustable plate to adjust the length of the Winch. The motor coupling chain is to be provided in the base compartment. The mechanical torque limiter is to be mounted on the motor shaft to stop transmission of motion from the motor to the Winch in case of excess load, thus preventing any damage to the Winch and any possible breakage of the rope. However, Single-phase Motors are also provided on demand. The structure consists of a working platform, ladder, and a cross arm for fixing Luminaires with bolts, as and when required.



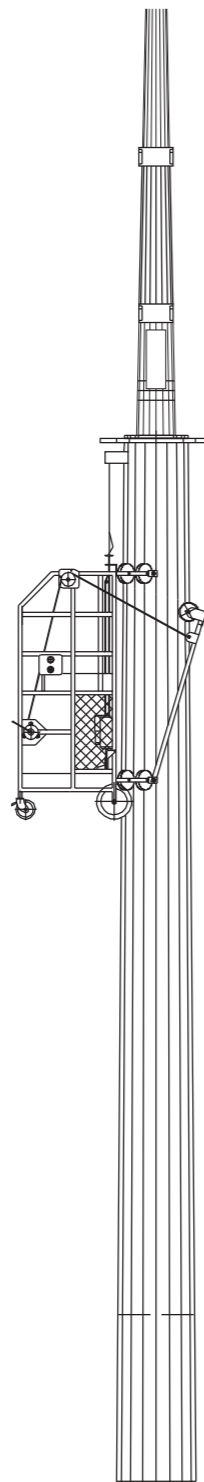

### MANRIDER

A cage unit (Manrider) for carrying the maintenance person to the top to access the Luminaires is placed on a fixed type Head Frame, used for sports/special applications. The unit is safe with a load-carrying capacity of 300 kg with a climb speed not exceeding 9 m/min.

## ELECTRICAL SYSTEM

The Mast's Feeder Pillar is used for the supply of power and to control its mechanical operations. Made up of 16 SWG CRCA sheets suitable for outdoor application, the Feeder Pillar conforms to a degree of protection IP54 as per IS 2147. Feeder Pillars are provided with a canopy and stand for mounting above ground level. The single front door is protected with a padlock arrangement. The single dial time switch and contactor for automatically switching on and off Luminaires, contactors with the interlocking arrangement, fuses/ MCB, and lower push buttons for raising motor operations are all provided for smooth operation. Termination facilities for the 50 sq mm incoming cable with Loop-in Loop-out arrangement and for the outgoing cables of 4 C 16 sq. mm for power and 2.5 sq mm for the motor are provided.

### FEEDER PILLAR

Standard Feeder Pillars are designed for input power supply of 3 phase 415 V 4 wire 50 Hz AC. Feeder Pillars with incoming power supply of 3 phase 3 wire 220 to 250 Volt 50 Hz AC and 3 phase 3 wire 415 Volt 50 Hz AC are available on demand. Feeder Pillars for flameproof applications are also available.

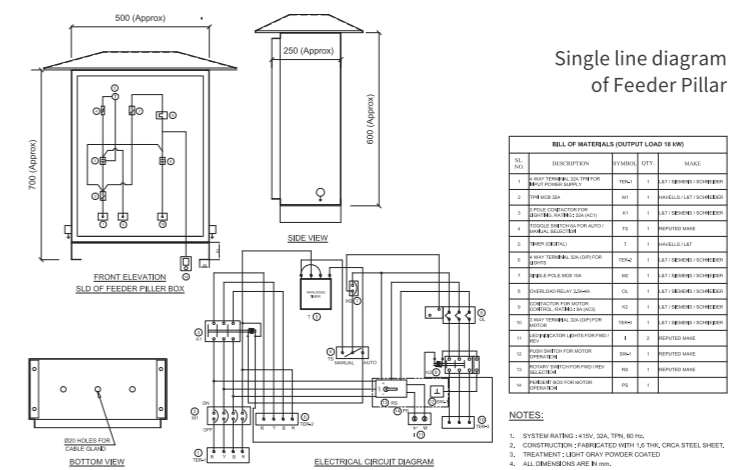



#### **TRAILING CABLE**

The multi-core Trailing Cable from MCB/Plug socket present at the base compartment, connecting with the Junction Box at the Luminaires Carriage shall be of 1.1 KV grade EPR insulated, PCP sheathed copper conductor with male-female connectors of minimum 5 core x 2.5 sq mm or above, depending on the load of the Luminaires Carriage.



#### **MOTOR CONNECTION CABLE**

1.1 KV grade 3 core 2.5 sq mm, copper conductor to be used for the connection of power supply from Feeder Pillar control circuit to Winch motor assembly at the base of the mast through the foundation.



#### **LIGHTING CONNECTION**

1.1 KV grade 4 core 16 sq mm, Aluminium conductor armoured cable to be used for connection of power supply from Feeder Pillar to the MCB/plug socket assembly at the base of the mast through the foundation.

#### **LUMINAIRES CONNECTION**

Wiring from the Junction Box to Luminaires is to be done using 3 core 1.5 sq mm PVC insulated, PVC sheathed, Copper conductor flexible cable.

#### **INCOMING POWER CABLE**

1.1 KV grade, PVC insulated, PVC sheathed, Aluminium conductor, armoured cable for power supply is provided for the purpose of masting by the user. Narrow beam long-throw LED/conventional flood light of suitable wattage is available on customer demand as per the technical specifications.







Designed  
To Excel  
For U

## DESIGN

### STRUCTURAL DESIGN

High Mast and Foundation Bolt designs conform to Technical Report no. 7 of ILE UK/PLG – 07 of ILP and IS 875 (Wind Loading) using a validated design process for each mast.

### FOUNDATION DESIGN

High Mast and Foundation Bolt designs conform to Technical Report no. 7 of ILE UK/PLG – 07 of ILP and IS 875 (Wind Loading) using a validated design process for each mast.

### MECHANICAL DESIGN

Upgradation of the mechanical design of the components using modern technology is an ongoing process for catering to customer demands.

### ELECTRICAL SYSTEMS

Designed to select electrical accessories of optimum rating to offer safe and long life for the different power supply and Luminaire arrangements.

## QUALITY

100% physical verification done during procurement. Periodic sample testing is performed by an NABL-accredited test house.

### RAW MATERIAL

100% testing is done for the Winch, Motor, Feeder Pillar, and light fittings. Periodic sample-testing of the Wire Rope is performed by NABL-accredited test house.

### BOUGHT OUT ITEM/IN-PROCESS & FINISHED GOODS

Sample-testing is done as per the Manufacturing Quality Assurance plan.



# Buyer's Guide

## HIGH MAST LIGHTING SYSTEM

- Uniform area lighting with 360-degree or 180-degree coverage for yards, airports, ports, road junctions, mines, industry settings, etc
- Access of light fittings by lowering down Lantern Carriage to man-height for maintenance
- Access of base compartment through the door for maintenance of the electrical items
- Single/double multi-core electrical cable for all floodlights
- 3 Wire Rope suspension system provides stable horizontal placement of Lantern Carriage
- 4 in-house seven-tank galvanization setups, each with 12.5 metre-long GI Bath
- Optional Head Frame latching system for extra security and stability

For use in –  
 Seaport  
 Airport  
 Car Parking  
 Container Yard  
 Rail Yard  
 Manufacturing Plant  
 Roadway Network  
 Switchyard

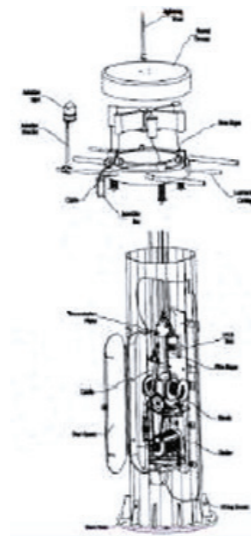

Mast Head Assembly with 3 rope head frame for 2/3 rope system

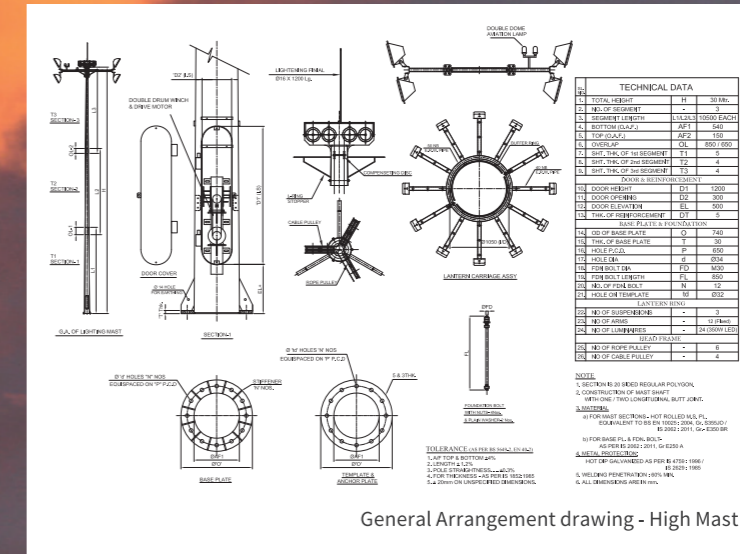

General Arrangement drawing - High Mast

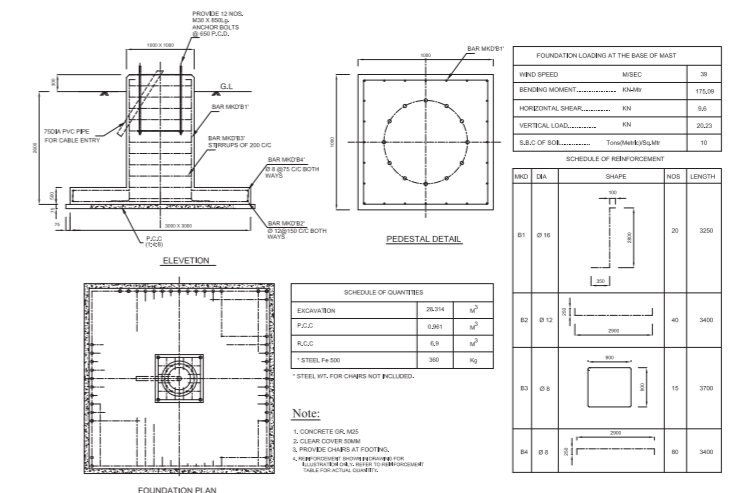

General Arrangement drawing - High Mast



## BUYER'S GUIDE HIGH MAST LIGHTING SYSTEM

Sr. No.	Height of Mast (in mtr)	No. of Luminaire	Top A/F (in mm)	Bottom A/F (in mm)	No. of Section	Section Length			Section Wise Thickness			Base Plate (in mm)	PCD (in mm)	Foundation Bolt Details	Approximate Weight of Shaft with Foundation Bolt (in kg)
						Top	Middle	Bottom	Top	Middle	Bottom				
1	10	4 to 6	100	310	2	5250	x	5250	3	x	3	470 X 25	390	6 Nos X M24 X 750 mm	
2	12	6 to 8	150	360	2	6250	x	6500	3	x	3	520 X 25	445	6 Nos X M24 X 750 mm	500 to 550
3	12.5	4 to 6	150	300	2	6500	x	6500	3	x	3	520 X 25	445	6 Nos X M24 X 750 mm	500 to 550
	12.5	6 to 8	150	360	2	6500	x	6500	3	x	3	520 X 25	445	6 Nos X M24 X 750 mm	500 to 550
4	16	6 to 8	150	360	2	8300	x	8300	3	x	3	540 X 25	445	8 Nos X M30 X 850 mm	650 to 750
	16	9 to 12	150	410	2	8300	x	8300	3	x	3	570 X 30	490	8 Nos X M30 X 850 mm	650 to 750
	16	12 to 16	150	460	2	8300	x	8300	3	x	4	670 X 30	590	8 Nos X M30 X 850 mm	800 to 950
5	20	6 to 9	150	360	2	10300	x	10300	3	x	4	540 X 30	460	8 Nos X M30 X 850 mm	800 to 950
	20	9 to 12	150	410	2	10300	x	10300	3	x	4	570 X 30	490	8 Nos X M30 X 850 mm	800 to 950
	20	12 to 16	150	460	2	10300	x	10300	3	x	4	670 X 30	590	8 Nos X M30 X 850 mm	800 to 950
6	25	9 to 12	150	460	2	8750	8750	10300	3	4	4	670 X 30	590	12 Nos X M30 X 850 mm	800 to 950
	25	12 to 16	150	480	3	8800	8800	8800	3	4	5	690 X 30	590	12 Nos X M30 X 850 mm	1200 to 2000
	25	16 to 20	150	540	3	8800	8800	8800	4	4	5	730 X 30	650	12 Nos X M30 X 850 mm	1200 to 2000
7	30	9 to 12	150	540	3	10500	10500	10500	3	4	5	740 X 32	650	12 Nos X M30 X 850 mm	1200 to 2000
	30	12 to 16	150	600	3	10500	10500	10500	4	4	5	840 X 36	740	12 Nos X M30 X 850 mm	1200 to 2000
	30	16 to 20	150	610	3	10500	10500	10500	4	5	6	840 X 36	740	16 Nos X M30 X 850 mm	1200 to 2000





# Buyer's Guide

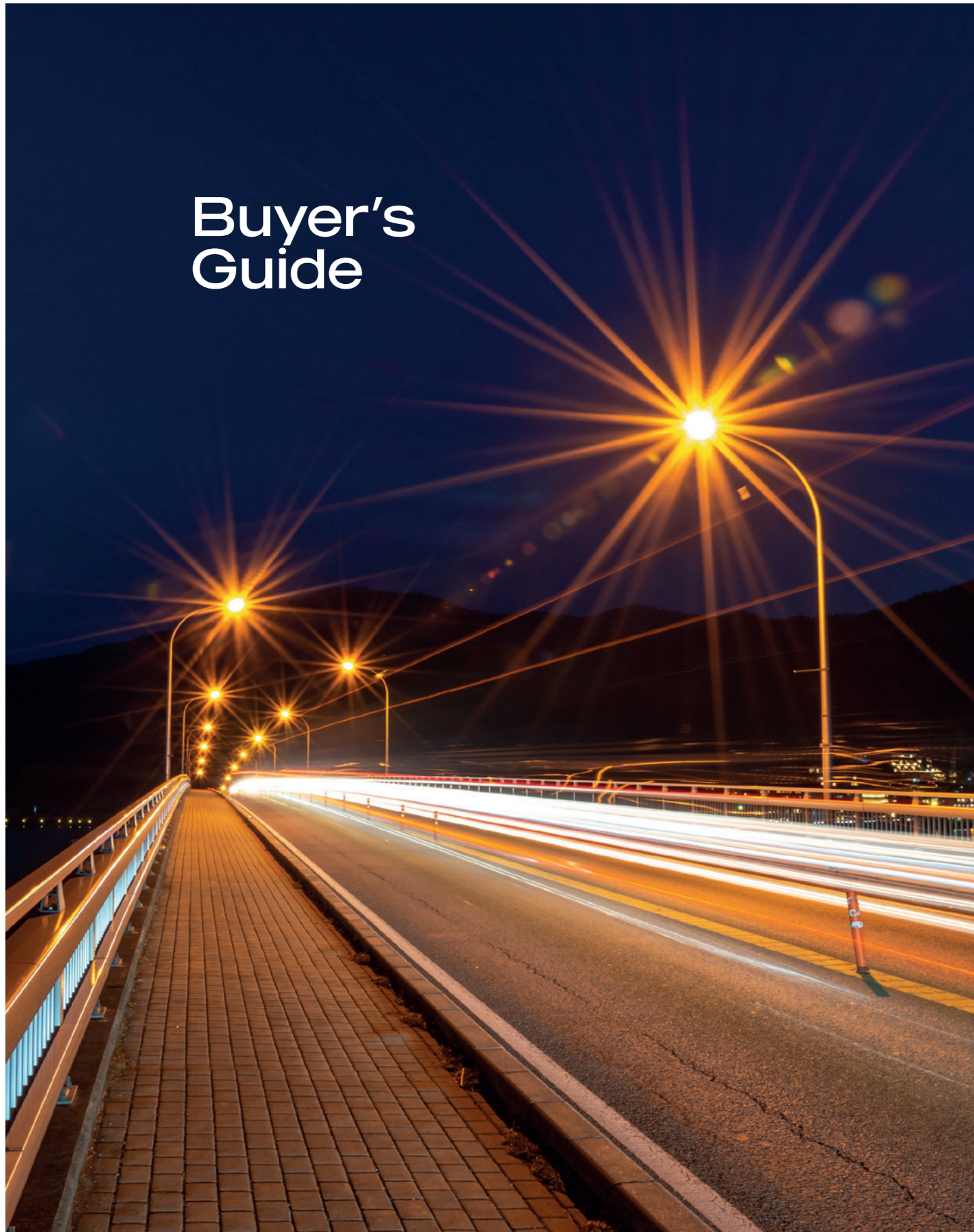

## FIXED HEAD FRAME WITH MANRIDER/LADDER

- Uniform area lighting with 180 degree coverage for sports, container yards, and seaside application areas
- Access to light fittings by a Ladder fixed on the body of the Mast Shaft or a Manrider moving the shaft to reach the maintenance platform at the top
- Access of base compartment through the door area, for maintenance of the electrical items
- Suitable to install more than 24 light fittings on a fixed Head Frame
- Used for outdoor sports lighting to meet the requirement for uniform high-intensity light levels

For use in –  
Stadium Lighting  
Jetty Lighting  
Apron Lighting

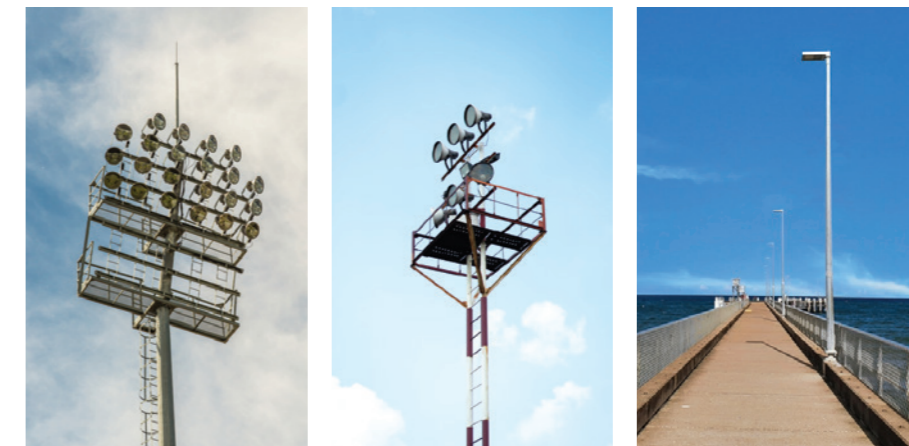



**BUYER'S GUIDE (SPORTS LIGHTING MAST WITH MANRIDER)**

Sr. No.	Height of Mast (mtr)	Maximum Head Load (kg)	Maximum Head Load Capacity (sq mtr)	No of LED Flood Light	Top A/F (in mm)	Bottom A/F (in mm)	No. of Section	Section Wise Thickness				Base Plate (in mm)	PCD (in mm)	Foundation Bolt Details	Approximate Weight of Shaft with Foundation Bolt (in kg)
								Top	Middle 1	Middle 2	Bottom				
1	20 - 22 mtrs	1100	5.3	16 X 500 W	300	500	3	4	5	-	6	670 X 36	590	M30 X 850 X 16	2800
	20 - 22 mtrs	1800	10	24 X 500 W	300	650	3	4	6	-	8	900 X 40	780	M33 X 1200 X 16	4000
2	30 - 32 mtrs	1500	7	16 X 1000 W	350	700	4	4	4	5	6	920 X 36	800	M39 X 1200 X 16	4500
	30 - 32 mtrs	1700	17	24 x 1000 W	360	1000	4	4	5	6	8	1220 X 36	1120	M33 X 1200 X 24	6500
	30 - 32 mtrs	1900	18	30 X 1000 W	400	1000	4	4	6	8	8	1250 X 50	1130	M39 X 1200 X 20	7000

**BUYER'S GUIDE (SPORTS LIGHTING MAST WITH LADDER ARRANGEMENT)**

Sr. No.	Height of Mast in mtr (Top of Head Frame)	Maximum Head Load (kg)	Maximum Head Load Capacity (sq mtr)	No of LED Flood Light	Top A/F (in mm)	Bottom A/F (in mm)	No. of Section	Section Wise Thickness				Base Plate (in mm)	PCD (in mm)	Foundation Bolt Details	Approximate Weight of Shaft with Foundation Bolt (in kg)
								Top	Middle 1	Middle 2	Bottom				
1	16 - 20 mtrs	1100	5.3	12 X 500 W	200	500	3	4	5	-	6	670 X 36	590	M30 X 850 X 16	3000
	16 - 20 mtrs	1100	5.3	16 X 500 W	300	500	3	4	5	-	6	670 X 36	590	M30 X 850 X 16	3300
2	20 - 20 mtrs	1800	10	24 X 500 W	300	650	3	4	6	5	8	900 X 40	780	M33 X 1200 X 16	4500
	28 - 32 mtrs	1500	7	16 X 1 000 W	350	700	4	4	4	6	6	920 X 36	800	M39 X 1200 X 16	5000
	28 - 32 mtrs	1700	17	24 X 1000 W	360	1000	4	4	6	8	8	1220 X 36	1120	M33 X 1200 X 24	7000



# Easy Installation

Since the components can be easily assembled at ground level, the installation of our High Mast is quick and hassle-free on the foundation, with the help of a crane/hydra/derrick.

## HOW TO INSTALL

Mast should be installed on M 25 grade concrete with steel reinforcement as per UIL reference foundation drawings. Galvanised foundation bolts are supplied with nuts, washers, and fixing templates.

### 1. ERECTION AND INSTALLATION PROCEDURE

- 1.1 Collect all the accessories (e.g., Head Frame, Lantern Ring, etc) of the High Mast at the erection site.
- 1.2 Check PCD and diameter of foundation bolts on the foundation. Then check the PCD and hole diameter of the base plate in the bottom section.

### 1.3 SECTION ASSEMBLY

- 1.3.1 Bottom section and middle section are placed horizontally on a round wooden block to insert the middle section approx. 20 mm into the bottom section.
- 1.3.2 A chain pulley block approximately 5 M/T is placed behind the base plate of the mast. The end of the chain pulley is fixed with the flange of the mast and the chain hook is fixed to the top end of the inserted section.
- 1.3.3 Then the sections are pulled by the chain block.
- 1.3.4 Care is to be taken to align the section properly to achieve correct insertion. The welding joint of each section has to be aligned with each other.
- 1.3.5 After proper sleeve joint assembly of the bottom and middle section, the same procedure is to be continued to join the top section.

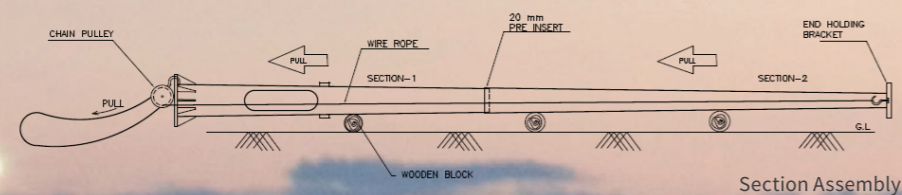

### 1.4 HEAD FRAME ASSEMBLY

- 1.4.1 The Head Frame of the mast is fitted on the top section.
- 1.4.2 The Wire Ropes and cables are inserted inside the mast with the help of a nylon rope which was initially inserted during the assembly of sections.
- 1.4.3 The compensating disc, power tools, and Winch Assembly are fixed inside the Mast.
- 1.4.4 The Wire Rope and the cables are passed on the pulleys of the Head Frame and attached to the stopper clamp welded on the Mast's Base section.
- 1.4.5 In the case of three-point suspension, the part of the cable pulley arrangement of the Head Frame is to be kept behind the door side and in the case of a two-point suspension, both pulley arrangements of the Head Frame have to be kept along the sides of the door.

### 1.5 FOUNDATION BOLT ARRANGEMENTS

Ensure the bolt threads are cleaned and greased and have one nut on each bolt within 15 mm bottom clearance from the base. Using a spirit level ensures that all the nuts stay in one plane.

### 1.6 ELEVATION OF ASSEMBLED MAST

The center of gravity of the mast should be determined and the sling should be placed in position just above the point. A straining Wire Rope with shackles is secured to the sling and a fixed hole is provided in the gussets (stiffeners). One further rope should be attached to the sling for assistance in the removal of the sling, for scenarios when the mast is firmly secured to the foundation bolt.

### 1.7 ERECTION OF MAST

The crane lifts the mast assembly on the foundation keeping the door on the required side; the supply cable is to be kept inside the mast.

### 1.8 TIGHTENING OF FOUNDATION BOLT

Nuts should be tightened properly. Ensure that two nuts in each foundation bolt are placed on the base plate (Lock Nut).

### 1.9 SLING PULLING

The straining wire can be removed from the gusset/stiffener. Then the sling is to be removed by pulling down the attached rope and straining the wire.



### 1.10 LANTERN RING ARRANGEMENT

The two halves of the Lantern Carriage are fitted with Luminaires, CG box, and Junction Box to complete the wiring arrangements.

### 1.11 RISING OF LANTERN RING

Operate the pendant switch to lift the Lantern.

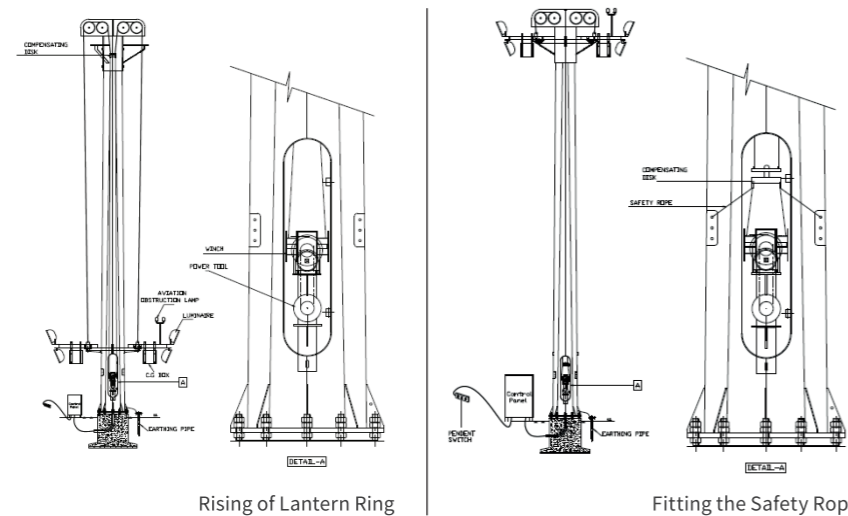

Components of the High Mast Lighting System are designed to make the system robust for outdoor operation in harsh weather conditions, yet easy enough to install, operate and maintain in remote areas, thereby effectively reducing the servicing time.

## Making Life Easy For U

Operating and maintaining our High Masts is easy and hassle-free, thanks to in-built features that allow quick access to the components at ground level. A service door at the bottom of the mast at a height of 500mm from the Base Plate makes the installed electrical components (Motor, Winch, MCB) easily accessible, thus speeding up maintenance work. The facility for lowering the Lantern Carriage also enables easy service of the Lighting Assembly & Junction Box.

### IN-BUILT FEATURES FOR MAINTENANCE & SERVICING

Easy access service points are provided at the Mast Base with an Allen-key locking arrangement to avoid pilferage.

### ROBUST SERVICE DOOR

Testing of light fittings at the down position of the Lantern Carriage is done when the trailing cable is open.

### TESTING LID

A Junction Box is placed at the top for the termination of the trailing and wiring cables.

### CLEAN & WEATHERPROOF CONNECTION

Easy movement of wiring cable is used for the Luminaire connection.

### HOLLOW LANTERN CARRIAGE RING

Used to hold the trailing cable.

### GROOVED CLAMP

Used to clamp the Wire Rope.

### GRIP & THIMBLE

For raising or lowering of the Mast at the time of power failure.





### MANUAL HANDLE

Fixed Ladder or Manrider is provided for easy access to the maintenance platform at the top.

### ACCESS TO LIGHT FITTINGS FOR THE FIXED-TYPE HEAD FRAME

A permanent oil bath allows the greasing of hard-to-reach locations of the Wire Rope.

### GREASING MADE EASY

A permanent oil bath allows the greasing of hard-to-reach locations of the Wire Rope.

### WINCH GEAR BOX

Used to move the worn shaft together with the integral Motor by chain sprocket and torque limiter.

### SUSPENSION SPACER

Used to avoid twisting of trailing cable.

### INTERLOCKING FOR LANTERN CARRIAGE MOVEMENT

The Electrical & Mechanical Interlocking System stops the Lantern Carriage above the door during lowering, and at the time of maintenance during raising, stops the Lantern Carriage after docking.

### MOTOR MOUNTING PLATE

For mounting the motor and adjusting the tension of the chain.

### TORQUE LIMITER

Used for mechanically tripping the system under overload & for safe docking of the Lantern Carriage.

### TRANSMISSION PLATE

Support change from 2 Wire Rope to 3 Wire Rope system.

### OPERATIONAL CONTROLS

Daily on/off operations are controlled by a timer contactor circuit. Timer operation is adjusted at the time of erection, however the setting can be changed afterwards as required.

### PREVENTIVE MAINTENANCE

Preventive maintenance of High Mast is simple and low in frequency (once in six months).

- Gear Box oil to be checked and topped up (Oil Capacity Max 200 ml). Replace with fresh oil every year.
- Clean Wire Rope and grease motor for smooth movement.
- Lowering down Lantern Carriage as per instructions given.
- Check and tighten the electrical connection of the Luminaire.
- Check and tighten the electrical connection of items in the Mast Base and Feeder Pillar.

### REPLACEMENT OF SPARES

Be sure that the earthing is properly done and then disconnect the Power Supply from the Feeder Pillar Box.

- Open the door cover and see that the Trailing Cable is clamped properly with SS Wire Rope.
- Disconnect the plug of the Trailing Cable and also the safety rope.
- Put the L-Stopper in stopper clamps.
- Hold the pendant switch off the power tool and keep yourself away at least 3 metres from the Mast Shaft.
- Select the reverse mode of the pendant switch and start operation initially by inching and observing the Lantern Ring come down. Then start the operation and observe the continuous motion of the Lantern Ring. If some difficulty is found during the operation, slightly lift the Lantern Ring in a forward direction and continue reverse operation.
- When the Lantern Ring comes down near the L-Stopper, start inching operation and stop it when it is properly docked.
- Once done, the Luminaires and other maintenance can be done safely.
- Test the whole circuit by giving a temporary supply to the Junction Box .
- Hold the power tool's pendant switch and select the forward mode initially by inching and observing the Lantern Ring go up.
- When the Lantern Ring reaches near the L-Stopper, then start inching the operation and stop it when it is properly docking.



# Component Specifications & Operation – Poles

## DESIGN

The Octagonal Poles shall be structurally designed to withstand the wind speed as per IS 875 Part – 3 - 2015. The top loading (weight of fixtures & bracket) is also considered during the calculation.

## POLE SHAFT

HT Steel Conforming to grade S355JO Base Plate FE410 conforming to IS 226 / IS 2062.

## DOOR

Poles shall have a door of 500 mm in length at the elevation of 500 mm from the Base Plate. However, the location of the door may be changed as per the requirement of the customer. The door is weatherproof and vandal resistant including an Allen key locking arrangement to ensure safety. Earthing nut is provided for the purpose of earthing.



## BASE PLATE

The bottom section of the poles is welded with a Base Plate of suitable thickness from both inside and outside. Base Plates are provided with holes for fixing 4 foundation bolts.

## NUMBER OF POLE SECTION

The Poles shall be in a single section up to 12 m. Pole sections above 12 m can be provided as custom requirement.

## GALVANIZATION

The poles shall be internally and externally hot dip galvanized as per IS 2629 / IS 2633 / BS EN ISO 1461 / BS729 / IS 4759 standards with a minimum of average coating thickness per recommendation through a single dipping process including door and base plate after surface treatment using 7-tank process.

## DESIGN LIFE

The standard design life of the pole is 25 years. Designs for a longer life are available and on demand.



## ACCESSORIES

### FOUNDATION BOLT

Four Galvanised Stainless Steel foundation bolts set of EN.8 grade in suitable diameter and length are provided with the Pole.

### BRACKET

The galvanised single arm/double arm brackets of different lengths and angles are provided as per customer requirement along with the Pole for installation of the Luminaires. However, three-arm and four-arm brackets are also available in our product range. Street lighting with single and double arm brackets are available in different arrangements (one side, staggered, opposite & central verge).

### ELECTRICAL CONNECTION

Pole is supplied with a facility to fix bakelite sheet behind the door for fixing electrical items like MCB, Fuse, Cable Termination kit, etc. However, we do not supply any electrical items with the pole.

### ERECTION

The Poles are to be bolted on a pre-cast foundation with a set of four foundation bolts for greater rigidity. Erection and foundation shall not be included in our scope.

### DECORATIVE BRACKET

A wide range of decorative brackets is available to suit the aesthetic requirements of the project site.

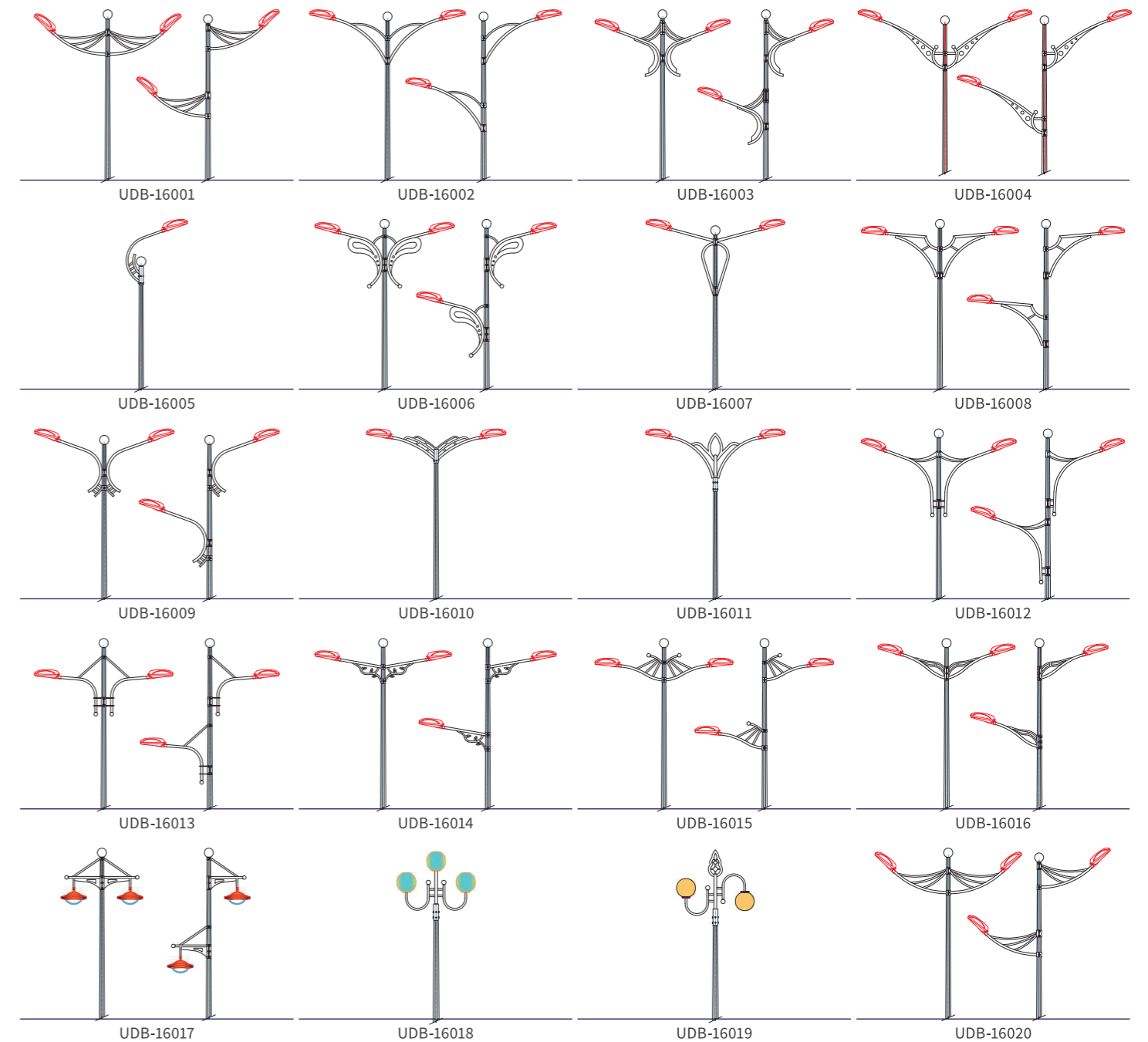



# Global Presence

- **China**
  - Guangzhou Hongli Opto-electronic Co. Ltd.
- **U.A.E**
  - Gargash Lighting Systems L.L.C.
  - Emia Baoli General Trading L.L.C.
  - Euro Asia Impex FZCO
  - RR Middle East FZCO
  - Advance Light Electrical Trading L.L.C.
  - Jupiter Electromechanical Contracting L.L.C.
- **Qatar**
  - Signmax Trading W.L.L.
  - Art & Built Solutions
- **Canada**
  - Signmax Trading W.L.L.
- **Oman**
  - Blue Chip Global L.L.C.
  - Jal Engineering Services L.L.C.
  - Technical Supplies International Company L.L.C.
- **Africa**
  - AF Pro Engineering Services
  - TOO Mains Contractors
  - Sotravic Ltd.
  - Avant Resources Ltd.
- **East Africa**
  - Balcon Uganda
- **Lebanon**
  - MK Trading
- **Turkmenistan**
  - Injener Chozgutleri
- **Nepal**
  - Contech Pvt. Ltd.
  - AMR Contech
  - Surya Roshni Construction Industrial Pvt. Ltd.
  - Nepal Power Solution Pvt. Ltd.
  - Gautam Buddha Electrical Company Pvt. Ltd.
  - E.U. International Pvt. Ltd.
  - Paaila Technology
  - Aarav Trade & International
  - Jagdamba Cement
  - Sunshine Energy Pvt. Ltd.
  - Himal Refrigeration & Electrical Industries Pvt. Ltd.
  - Mahavir Shree International Pvt. Ltd.
  - SRCIPL
  - Riya International
  - Topsun Energy Ltd.
- **Bhutan**
  - Thimphu Light House
  - Sherub Dorji Construction
  - Bhutan Hardware Agency
  - Druk Ngawang Dorji Construction
- **Sri Lanka**
  - Abans Engineering

# National Presence

- Digha Sankarpur Development Authority
- Haldia Development Authority
- NTPC Farakka
- Ministry Of Defence (Eastern Command)
- Sail
- CPWD Border Lighting
- South Dumdum Municipality
- Paradeep Port Trust
- JSW Steel Ltd, Bhadrasahi, Barbil, Keonjhar
- Adani Port, Dhamra Port
- East Coast Railway, Khurda
- NTPC, Barh
- Bihar State Power Holding Company Ltd.
- IOCL, Barauni Refinery
- Tata Steel & Jusco
- Urja Bibhag, Ranchi
- Delhi Development Authority
- Delhi Metro Rail Corporation
- Upsida
- Agra Development Authority
- Nuclear Power Corporation Of India Ltd.
- Gail Pata
- Power Grid, Satna
- Gwalior Krishi Mandi
- Baerlocher Chemicals, Dewas
- MP Road Development Corporation, Sagar
- Bilashpur Smart City
- South East Central Railway, Bhatapara
- NHAI (Raipur-Bilaspur Road Project)
- Adani Raigarh Power Ltd, Raigarh
- Pimpri-Chinchwad Municipal Corporation
- NHAI, Shirdi
- Adani Dighi Port, Mumbai
- Adani Logistics Ltd, Taloja, Mumbai
- MIDC, Chakan, Ahmednagar
- NHAI, NKC Project Pvt. Ltd.
- HPCL - Barmer Refinery
- RIICO, Jaipur
- North Western Railway Workshop, Bikaner
- Mussoorie Dehradun Development Authority
- Power Development Department
- JKPDCL Corporate
- Kashmir Power Distribution Corporate Ltd.,
- Amarnath Project Nhαι (Nha-1 Quazigund-banihal Project)
- NHAI / Tata Project
- Adani Krishnapatanam Port Ltd. Krishnapatanam
- RNB Department, (CM's Constituency, Pulivendula)
- Visakhapatnam Port Trust
- VSP, Visakhapatnam
- BBMP & HDMC
- Shivamogga Smart City Project
- HAL, Bangalore
- Karnataka Rural Infrastructure Development Limited
- CPWD, Chennai Trade Centre
- Southern Rly, Tiruchirapalli
- Adani Katupalli Port, Chennai
- Vellore Municipal Corporation
- National Highways Development Programm
- (Oddanchatram – Madathukulam Section Of NH- 209 (New NH-83)) National Highways Development Pprogramme
- (Kazhakkottam To Mukkola Section )
- Power Department, Sikkim
- Guwahati Smart City
- IOCL, Digboi Refinery
- Ministry Of Defence (Eastern Commend)
- Deputy Commissioner East Jaintia Hills
- Airport Authority, Agartala
- MES Agartala
- Govainda Temple, Imphal
- Singda Dam, Imphal
- North Western Railway
- Kartarpur Corridor, Indo-Pak Border
- Grater Mohali Area Development Authority (Gamada)
- Greater Ludhania Development Authority
- HUDA
- NTPC, Faridabad
- HIIDC
- Adani Port, Mundra / Adani Hazira Port, Surat
- Adani Mundra Port, Kutch
- Nayara Energy Ltd / Essar Oil Ltd., Jamnagar
- Krishak Bharati Cooperative Ltd., Surat
- Surat Municipal Corporation
- Goa Electricity Department
- PWD, Itanagar
- R&B Department
- Manimahes Temple, Chamba



# From Commitment To Fulfilment

## SOME OF OUR HIGH MAST PROJECTS

### Supply of Solar Poles in 38 ULB's of Assam for DMA Assam, Dispur

Adequate street lighting is a basic requirement in towns and cities, but large areas of Assam do not have these facilities, which causes the citizens are much inconvenience. To address this problem, the Govt. had taken up a unique project to install Energy Efficient LED lights in all the ULBs of Assam. Utkarsh India supplied 3000 Octagonal Poles of 7 mtrs height, suitable for fixing solar LED street lighting. We accomplished this dispatch within 1 month to different locations in Assam.

### Spine Street Light Project under GSC

Spine roads are arterial roads that include major and medium traffic roads of the city from where lanes and by-lanes emanate. The calculated total length of spine roads in Guwahati city is 250 kms approximately. Utkarsh India supplied 4000 Octagonal Poles of 6 and 10 mtrs under this project, which was completed and delivered at a record-breaking pace. What's more, the project was acknowledged as the best completed project for smart cities in the east.

### Supply, Installation & Commissioning of High Mast Lights at different places of Khilarihat, Meghalaya

Khilarihat in Meghalaya is a coal belt with heavy traffic movement. The area is always covered in coal dust with almost zero visibility of roads. Again, the terrain and the road conditions make it very difficult for projects to be commissioned faster. We received an order for SITC of 12 mtrs and 30 mtrs High Mast lighting systems. In spite of the tough conditions, we successfully completed the project in 1 month, including supply, installation and commissioning.

### Supply, Installation & Commissioning of High Mast Lights at Panagarh Camp and Misa Camp, West Bengal

We received an order for installation and commissioning of this very prestigious project under the Ministry of Defence Eastern Command, to be completed in a month. We undertook this challenge and have successfully commissioned it within the committed timelines.

### NHAI Project Jodhpur Pakage 05

We received an order from National Highway Authority of India (NHAI) for the supply of 10 mtrs Octagonal Poles with Brackets, for the newly-constructed Bharatmala project connecting Rajasthan to the rest of India. The challenge was to keep up with the pace of the road construction which was going on at about 8 km per week. We successfully kept this pace and had the project commissioned within the committed time.





# Certification

**DNV**  
MANAGEMENT SYSTEM  
CERTIFICATE

This is to certify that the management system of  
**Utkarsh India Limited**  
has been found to conform to the Environmental Health and Safety Management System standard  
**ISO 9001:2015**

The certificate is valid for the following scope:  
Manufacture of towers & accessories and  
assembly & erection of towers & accessories  
and related services

**DNV GL**  
Tower Testing & Research Station  
CSR-Structural Engineering Research Centre  
Council of Scientific & Industrial Research  
CSIR Campus, Triruvananthapuram, Kerala-695 022, India

Page 1 of 2

**LOAD CELL CALIBRATION REPORT**  
Date: 01-08-2022

1. CLIENT: M/S. UTKARSH INDIA LIMITED, KERALA  
2. MANUFACTURER: M/S. UTKARSH INDIA LIMITED, ARABY SQUARE, MA, SEELAYANGAL, KERALA, INDIA  
3. PROJECT TITLE: TYPE TESTING OF TOWER  
4. POLE DETAILS: 100MM DIA. TOWER WITH ALL ACCESSORIES  
5. SERIAL NO.: CS-08-1004  
6. DRAWING NO.: M/S. UTKARSH INDIA LIMITED, KERALA  
7. APPLICABLE STANDARDS: IS 875(P), IS 875(P), IS 875(P), IS 875(P), IS 875(P), IS 875(P)  
8. PRODUCT(S): TOWER

Load Cell	Rated Capacity	Load (N)	Output (mV/V)
1	1000	100	1.00
2	1000	200	2.00
3	1000	300	3.00
4	1000	400	4.00
5	1000	500	5.00
6	1000	600	6.00
7	1000	700	7.00
8	1000	800	8.00
9	1000	900	9.00
10	1000	1000	10.00

**DNV GL**  
Tower Testing & Research Station  
CSR-Structural Engineering Research Centre  
Council of Scientific & Industrial Research  
CSIR Campus, Triruvananthapuram, Kerala-695 022, India

Page 2 of 2

**PROVISIONAL TEST REPORT**  
Date: 01-08-2022

1. CLIENT: M/S. UTKARSH INDIA LIMITED, KERALA  
2. MANUFACTURER: M/S. UTKARSH INDIA LIMITED, ARABY SQUARE, MA, SEELAYANGAL, KERALA, INDIA  
3. PROJECT TITLE: TYPE TESTING OF TOWER  
4. POLE DETAILS: 100MM DIA. TOWER WITH ALL ACCESSORIES  
5. SERIAL NO.: CS-08-1004  
6. DRAWING NO.: M/S. UTKARSH INDIA LIMITED, KERALA  
7. APPLICABLE STANDARDS: IS 875(P), IS 875(P), IS 875(P), IS 875(P), IS 875(P), IS 875(P)  
8. PRODUCT(S): TOWER

S. No.	TEST CONDITION	TEST DATE	RESULT	REF.
1	OPERATIONAL LOADING CONDITION	01/08/2022	SUCCESSFUL	IS 875(P), IS 875(P)
2	SEVERE LOADING CONDITION	01/08/2022	SUCCESSFUL	IS 875(P), IS 875(P)
3	ULTIMATE LOADING CONDITION	01/08/2022	SUCCESSFUL	IS 875(P), IS 875(P)

**DNV-GL**  
MANAGEMENT SYSTEM  
CERTIFICATE

This is to certify that the management system of  
**Utkarsh India Limited**  
has been found to conform to the Quality Management System standard  
**ISO 9001:2015**

The certificate is valid for the following scope:  
Manufacture of towers & accessories and  
assembly & erection of towers & accessories  
and related services

**SGS**  
170088

RELEASE NOTE

This is to certify that the management system of  
**Utkarsh India Limited**  
has been found to conform to the Quality Management System standard  
**ISO 9001:2015**

**JADAVPUR UNIVERSITY**  
Faculty of Engineering & Technology  
Jadavpur Engineering College  
Jadavpur University, Kolkata - 720 016, India

**TEST REPORT**

The work done has been found to be satisfactory along with design calculation done in accordance with Code of Practice of Proposed 50 meter lighting pole. The design calculation and workmanship are in accordance with the code provision with that work will be followed as per requirement given in IS 875(P). The calculation and drawing are found to be in order and the structure should be safe and stable if properly fabricated and constructed with required specification.

**INDIAN INSTITUTE OF TECHNOLOGY KHARAGPUR**  
BUREAU OF INDIAN STANDARDS  
INDIAN INSTITUTE OF TECHNOLOGY KHARAGPUR  
Kharagpur - 751 002, India

**TEST REPORT**

The work done has been found to be satisfactory along with design calculation done in accordance with Code of Practice of Proposed 50 meter lighting pole. The design calculation and workmanship are in accordance with the code provision with that work will be followed as per requirement given in IS 875(P). The calculation and drawing are found to be in order and the structure should be safe and stable if properly fabricated and constructed with required specification.

**QMS**

The work done has been found to be satisfactory along with design calculation done in accordance with Code of Practice of Proposed 50 meter lighting pole. The design calculation and workmanship are in accordance with the code provision with that work will be followed as per requirement given in IS 875(P). The calculation and drawing are found to be in order and the structure should be safe and stable if properly fabricated and constructed with required specification.

**NSIC TECHNICAL SERVICES CENTRE**  
NSIC TECHNICAL SERVICES CENTRE  
NSIC TECHNICAL SERVICES CENTRE  
NSIC TECHNICAL SERVICES CENTRE  
NSIC TECHNICAL SERVICES CENTRE  
NSIC TECHNICAL SERVICES CENTRE

**TEST REPORT**

The work done has been found to be satisfactory along with design calculation done in accordance with Code of Practice of Proposed 50 meter lighting pole. The design calculation and workmanship are in accordance with the code provision with that work will be followed as per requirement given in IS 875(P). The calculation and drawing are found to be in order and the structure should be safe and stable if properly fabricated and constructed with required specification.

**Report Documentation Page**

1. Report Date: 01/08/2022  
2. Report Title: Tower Testing & Research Station  
3. Report Number: 170088

4. Title: Final report of tower testing & research station

5. Author: K. Pullar  
6. Sponsoring Agency: Utkarsh India Limited  
7. Distribution Statement: Limited  
8. Abstract: The report describes the test method, test results, and conclusions of the tower testing & research station. The test results show that the tower is safe and stable under the test conditions. The conclusions are that the tower is safe and stable under the test conditions.

9. Key words: Tower testing & research station, tower testing & research station, tower testing & research station

10. Security Classification of Report: Limited  
11. Reviewed by: K. Pullar  
12. Approved by: K. Pullar  
13. Date Authorized by: K. Pullar  
14. No. of Pages: 1